

# Manual 52STE SE

2+1 SPEED  
12V & 24V

**GENEREL INFORMATION**  
**MOUNTING INSTRUCTION**  
**EXPLODED VIEW**  
**PARTS LIST**  
**CONNECTING DIAGRAM**  
**WIRE DIMENSION AND FUSE SIZE**  
**WORLD WIDE DISTRIBUTION LIST**



SERIAL NO: PS \_\_\_\_\_

# CONGRATULATIONS

You have purchased an ANDERSEN high quality winch. This product is a result of many years of development and experience in producing winches for sailboats. This winch gives you a high degree of functionality and many years of safe and easy sail handling.

## GENERAL INFORMATION

### PLEASE READ THIS BEFORE INSTALLING YOUR ANDERSEN ELECTRIC WINCH.

The electric ANDERSEN winch has some built-in advantages:

- Easy to fit on your boat.
- Template included.
- Special tools included.
- Electric unit is turnable in 8 horizontal steps (45°).
- Easy to dismantle. Winch and electric unit can be dismantled separately.
- Winch in the usual high **ANDERSEN** quality, featuring drum, roller bearings etc. of stainless steel.
- Always the possibility of manual (2 speed) drive, just by inserting a standard winch handle. No shift-bottom of any kind.
- MODULAR POWER SYSTEM©: Always the possibility of changing to a hydraulic drive unit or from 2+1 SE to 2+2 or the Compact© electric drive unit.

#### Mounting Installation:

Please follow the mounting instructions.

Ensure that each hole in the deck is bedded, including the big hole in the center.

**IMPORTANT:** Be careful not to put bedding compound IN the thread holes in the deck plate.

Ensure that the sealing ring (O-ring) on top of the gear unit is placed in its groove.

#### Electric Installation:

Please follow the mounting instructions.

**WARNING:** Do not use smaller wire, than recommended in the diagram. This can cause malfunction of the winch and in worst case - FIRE. The wires should always be as short as possible.

#### Normal Use:

The electric motor has built-in overload circuit breaker, which breaks the circuit, before the motor gets too hot.

After a short period of cooling, depending on temperature under deck, ventilation etc., the winch will be ready for electrical operation again.

Meanwhile, if necessary, just insert a standard winch handle, and use the winch as a 2 speed manual winch. We recommend to remove the handle when operated electrically - from a safety point of view.

#### General Service Instructions:

The electric drive unit is lubricated & sealed and requires no further maintenance.

The part *on* deck is a standard self tailing winch, and needs regular service. We recommend dismantling, cleaning and lubrication *once* a year. Under extensive use, such as racing, charter or blue water sailing, we recommend to make a further lubrication check during the one year period.

We strongly recommend always to use ANDERSEN WINCH GREASE© when lubricating your winch.

ANDERSEN WINCH GREASE© is a high quality silicone/Teflon® grease.

# MOUNTING INSTRUCTION

52 STE SE  
2+1 SPEED

FIG.1

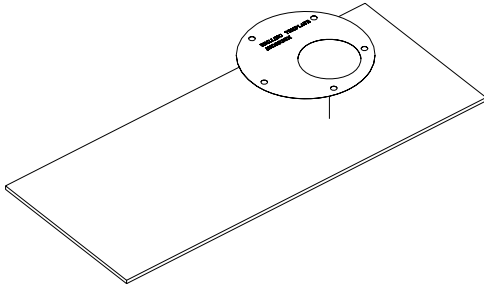

FIG.3

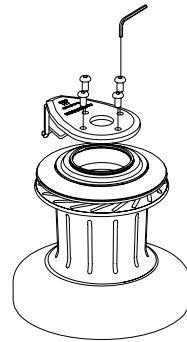

FIG.2

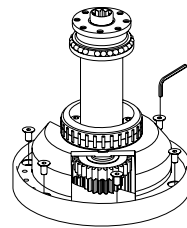
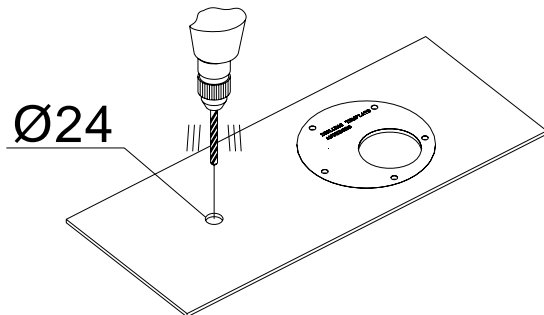
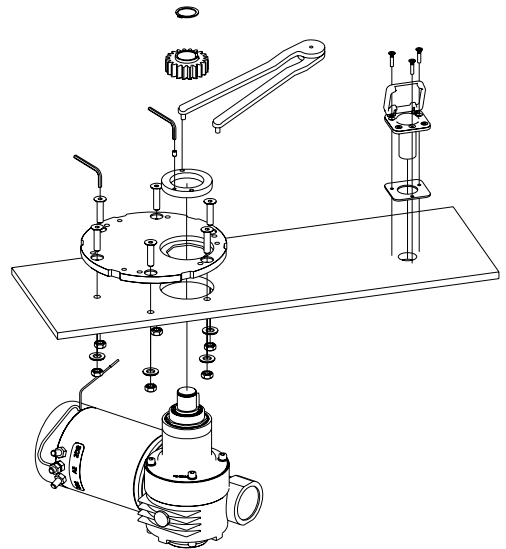
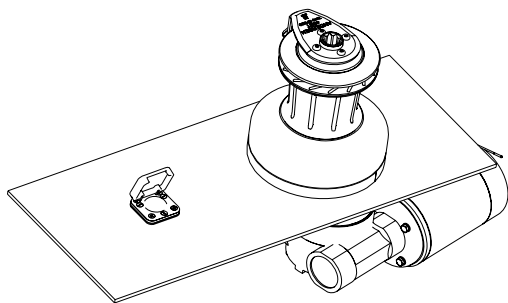

FIG.4



# Important Installation Information!

It is extremely important that your motor is aligned with your winch. Non-aligned motors will be noisy and gear wear will be accelerated.

To insure that your motor is aligned properly the motor flange must be flush with the deck plate and the eight-sided nut must fit snugly into the octagon in the deck plate.

This can be achieved with the help of the following:

- Drill the hole through the deck wider than the motor flange. When mounted there must be free space between the deck and the flange.
- Clean the deck hole before attempting to install the motor so that the motor flange does not catch splinters of fiberglass or wood when being inserted through the deck.
- Insure that the underside of the deck plate is clean and free from resin, varnish or sealants.
- Do not use a sealant between the flange and deck plate. An o-ring insures a waterproof connection. Extra waterproofing can be achieved by applying sealant to the top of the deck plate next to the mounting nut after installation.
- Insure that the locking screw on the mounting nut is not protruding beyond the contact surface before tightening the mounting nut. Tighten the locking screw when the mounting nut is securely in place.

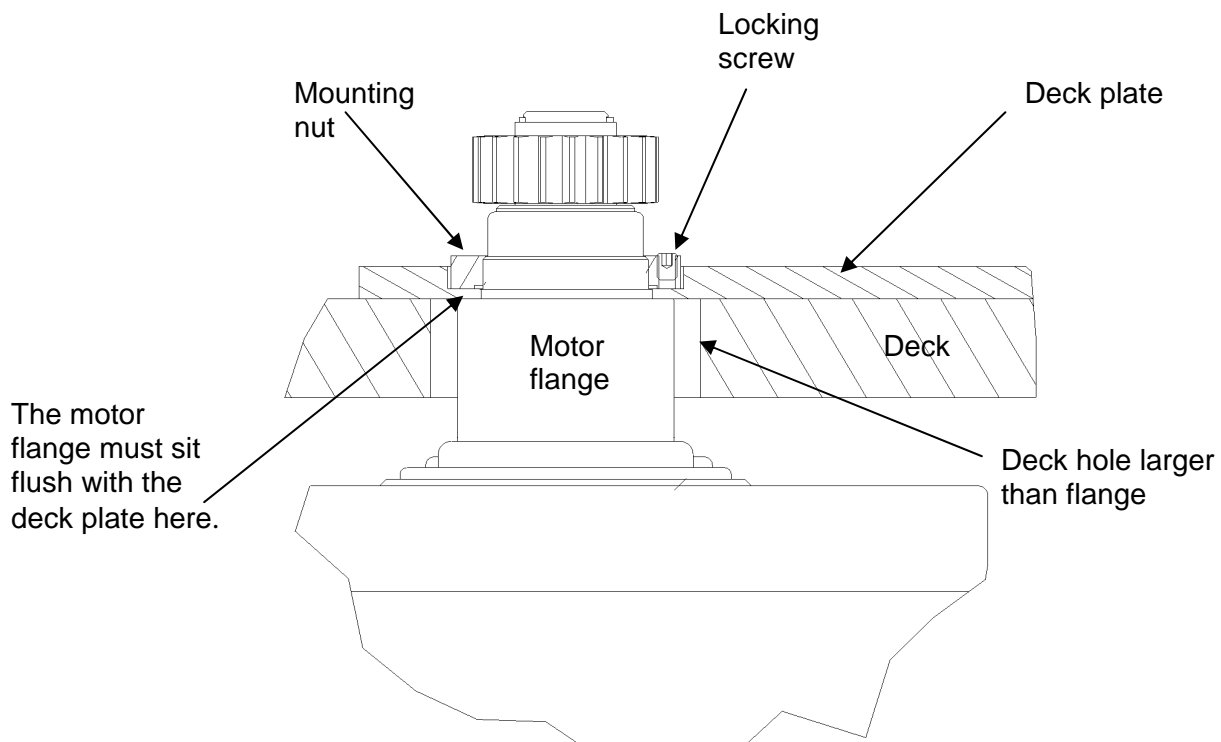

# EXPLODED VIEW

52 STE SE  
2+1 SPEED

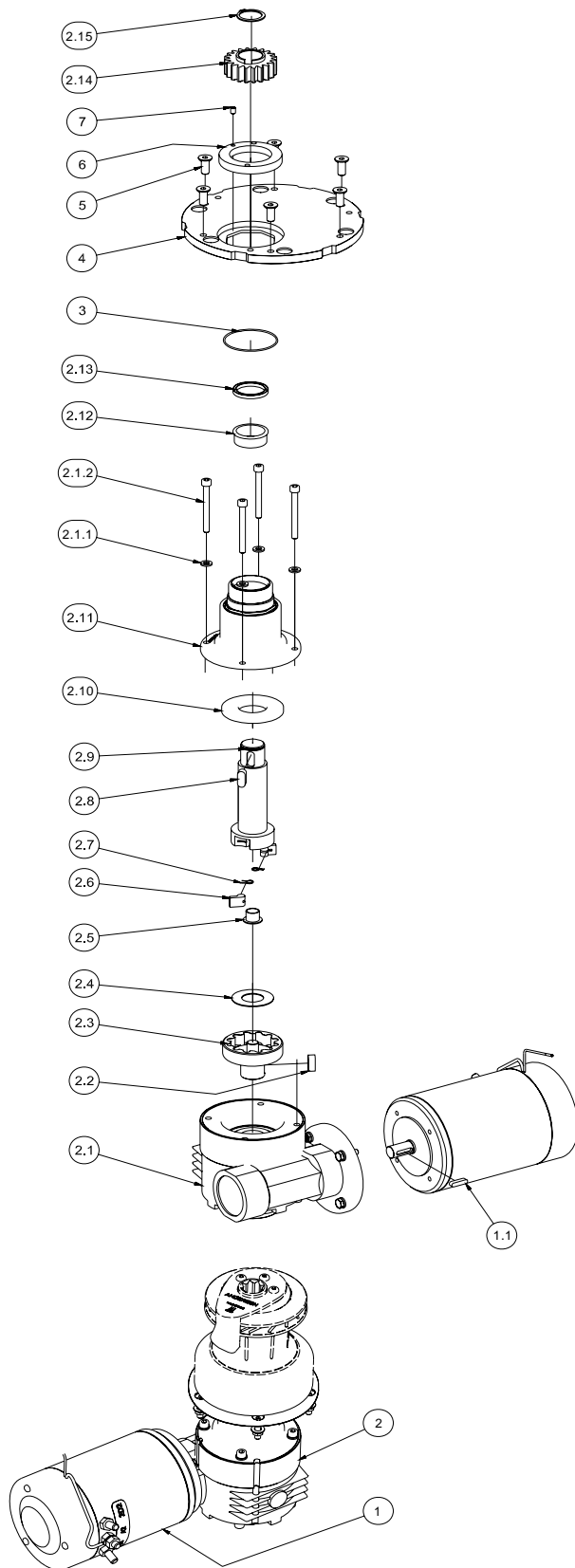

## ACCESSORIES

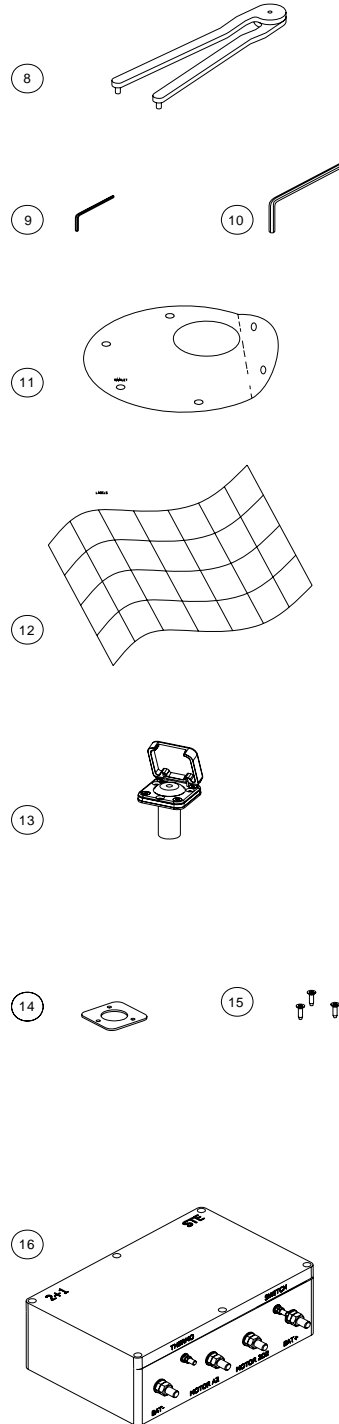

# PARTS LIST

52 STE SE  
2+1 SPEED

POS.	QTY.	DESCRIPTION	ART. NO.
	1	<b>Gear complete 52STE TYPE SE</b>	<b>777080</b>
1.	1	<b>Motor CIMA 1200W 12V STE SE</b>	<b>777320</b>
1.	1	<b>Motor CIMA 1200W 24V STE SE</b>	<b>777330</b>
1.1	1	Key	DIN6885-A-5X5X20
2.0	1	<b>Gear Unit 52STE SE</b>	<b>776140</b>
2.1	1	Gear i36 VF49	776220
2.1.1	4	Washer	DIN125-A4-Ø6
2.1.2	4	Screw	DIN912-A4-M6x55
2.2	1	Key	DIN6885-A-8X7X20
2.3	1	Ratchet gear	775860
2.4	1	Washer	835000
2.5	1	Bushing	RD100439
2.6	2	Pawl	713200
2.7	2	Pawl spring	713300
2.8	1	Key	DIN6885-A-8X7X20
2.9	1	Drive shaft	837000
2.10	1	Washer	775890
2.11	1	Drive shaft housing	775850
2.12	1	Bushing	823100
2.13	1	Sealing ring	RD100169
2.14	1	Gear wheel	981500
2.15	1	Circlip	RD829680
3.	1	O-ring	RD100074
4.	1	Deck plate 52STE	746902
5.	6	Screw	580100
6.	1	Center nut	584502
7.	1	Locking Screw	DIN916-A4-M5x8
8.	1	Pin spanner	RD738000
9.	1	Allen key	593000
10.	1	Allen key	592900
11.	1	Template 52STE	RD100327
12.	1	Switch labels	RD100029
13.	1	Switch	RD581900
14.	1	Sealing	735050
15.	3	Screw	RD100025
16.	1	Control box 12V	990212
16.	1	Control box 24V	990224

# CONNECTING DIAGRAM

12V + 24V  
52 STE SE  
2+1 SPEED

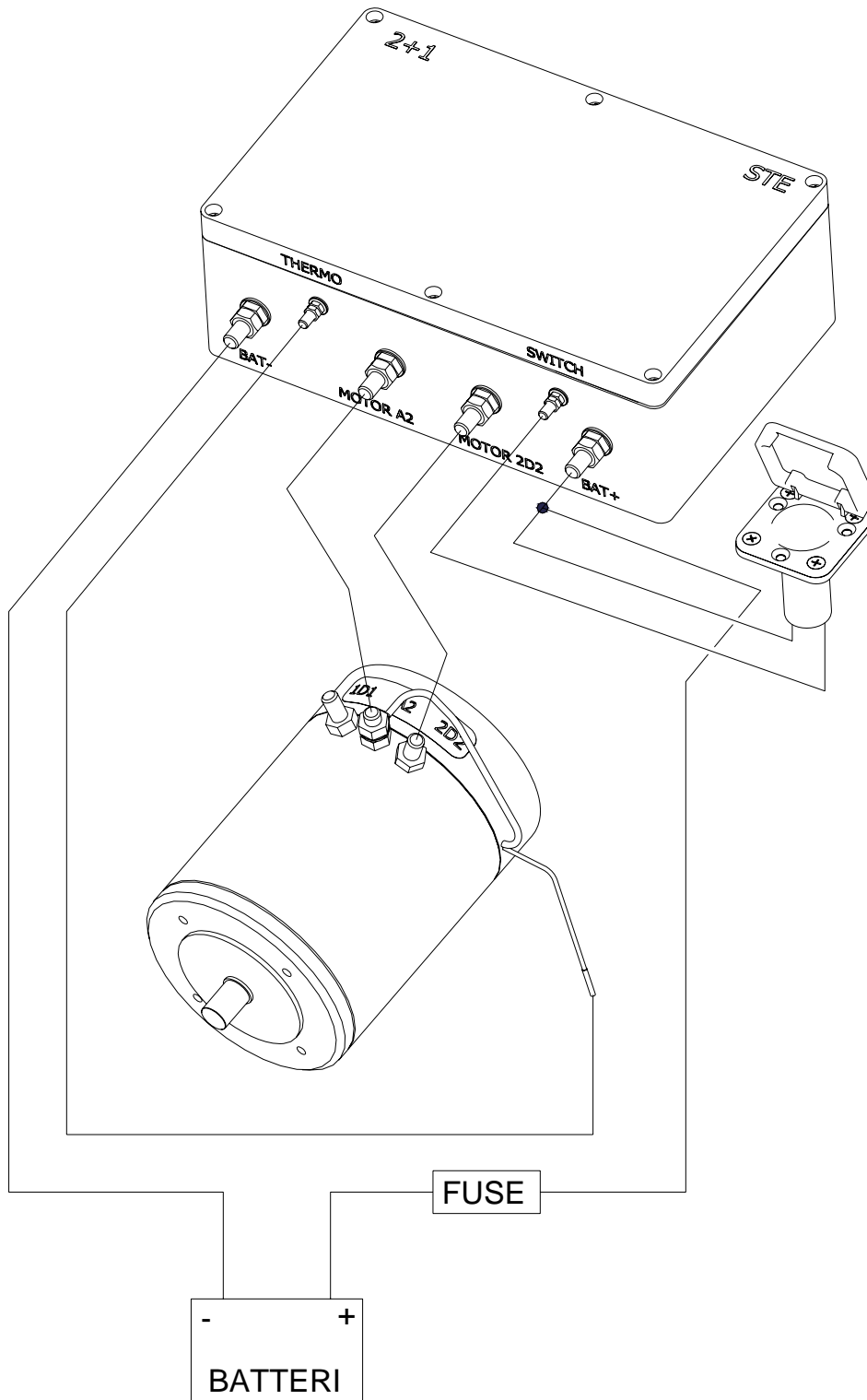

**IMPORTANT:** Do not use connection 1D1

**REMARK:** Fuse must be of a slow blow type

# MINIMUM WIRE DIMENSIONS & FUSE SIZES

(Not for continuous service)

WINCH	WIRE LENGTH*	12V. DC			24V. DC		
		WIRE	FUSE	BAT. CAP.	WIRE	FUSE	BAT. CAP.
28 STE SE	0-3 m / 0-10 ft	35 mm <sup>2</sup>	125 A	240 Ah	25mm <sup>2</sup>	76 A	120Ah
	3-8 m / 10-27 ft	50 mm <sup>2</sup>	160 A	240 Ah	25mm <sup>2</sup>	100 A	120Ah
40 STE SE	0-3 m / 0-10 ft	35 mm <sup>2</sup>	125 A	240 Ah	25mm <sup>2</sup>	76 A	120Ah
	3-8 m / 10-27 ft	50 mm <sup>2</sup>	160 A	240 Ah	25mm <sup>2</sup>	100 A	120Ah
46 STE SE	0-3 m / 0-10 ft	50 mm <sup>2</sup>	160 A	360 Ah	25mm <sup>2</sup>	100 A	180Ah
	3-8 m / 10-27 ft	70 mm <sup>2</sup>	200 A	360 Ah	35mm <sup>2</sup>	125 A	180Ah
52 STE SE	0-3 m / 0-10 ft	50 mm <sup>2</sup>	160 A	360 Ah	25mm <sup>2</sup>	100 A	180Ah
	3-8 m / 10-27 ft	70 mm <sup>2</sup>	200 A	360 Ah	35mm <sup>2</sup>	125 A	180Ah

\*) WIRE LENGTH is defined as the distance from battery to switch box + the distance from switch box to motor.

IMPORTANT: Fuse must be of a slow blow type.

For current World Wide Distributor list, please see:  
[www.andersenwinches.com](http://www.andersenwinches.com)