

MANUAL

12ST – 12ST FS

Version 3.0 Version 1.0



CONGRATULATIONS

You have purchased an ANDERSEN high quality winch. This product is a result of many years of development and experience in producing winches for sailboats. This winch gives you a high degree of functionality and many years of safe and easy sail handling.

TILLYKKE

De har købt et ANDERSEN spil af høj kvalitet. Dette produkt er et resultat af mange års udviklingsarbejde samt erfaring indenfor produktion af spil til sejlbåde. Med dette spil får De funktionalisme på højt plan med henblik på at yde Dem en behagelig samt sikker sejlads.

Sehr geehrter ANDERSEN kunde,

wir beglückwünschen Sie zu dem kauf einer ANDERSEN Winde, ein Produkt höchster Qualität, daß ein Resultat jahrelanger Entwicklungsarbeit und Erfahrung in der Produktion von Winden für Segelboote ist. Die funktionalität dieser Winde ermöglicht Ihnen viele Jahre lang eine handliche und sichere Segelführung.

FÉLICITATIONS

Vous venez d'acheter un winch ANDERSEN de grande qualité. Ce produit est le résultat de longues années d'expérience et de développement dans la production des winches pour voilier. Ce winch vous apportera de nombreuses années de fonctionnement sécurisant, pour une voile facile.

Frode Andersen
Managing Director

GENERAL INFORMATION

Due to the best choice of materials and high precision in manufacturing, we recommend, for normal use, only to dismantle, clean and lubricate the winch once every second year. Under extensive use, such as racing, charter or blue water sailing, we recommend to lubricate the winch once every year.

We strongly recommend always using ANDERSEN WINCH GREASE, when lubricating your winch. ANDERSEN WINCH GREASE is a high quality silicone/Teflon grease product. Most other types of grease, including “marine grease” are not suitable for lubrication of winches. Non-suitable grease products can cause malfunction, which could result in fatal injuries for the user and others.

Pawl arm springs should be replaced every second year. Spare arm springs and other parts that may be required are included in the ANDERSEN Service Kit. Please refer to the service instruction for the Service Kit suitable for the specific winch.

When the winch handle is not in use but the winch is under load, we recommend, from a safety point of view, to remove the winch handle from the winch.

To ensure correct function of the self-tailing unit, only use recommended line sizes. When using the winch with mooring lines **DO NOT** use the self-tailing function and be sure that the mooring line is not in contact with the self-tailing arm.

To ensure the best possible functioning of the winch, we recommend that the winch is placed in accordance with the line entry shown below.

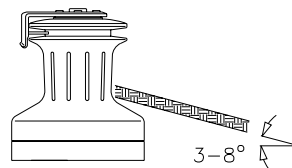

Be also aware that self-tailing arm is positioned correctly. We recommend having the self-tailing arm positioned within the shaded area. On 12ST and 28ST the position of the self-tailing arm is fixed, making it very important to establish the proper location of the holes prior to drilling these in the deck. On all other models, the self-tailing arm can be placed in several different positions after having installed the winch.

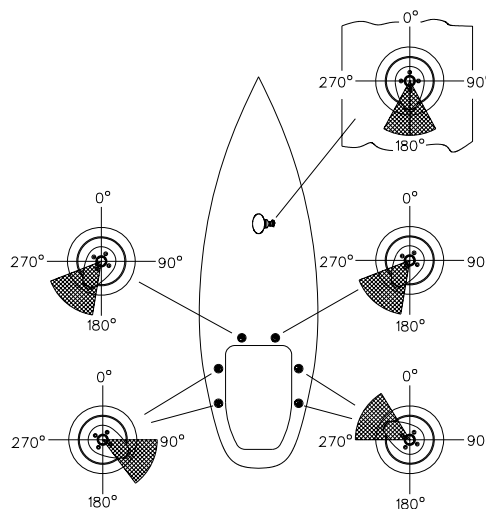

INSTALLATION

12ST ver. 3.0 – 12ST FS ver. 1.0

Installing the winch is easy, if you follow these instructions. The numbers in () refer to the position numbers in the parts list.

Tools required for the installation:

Allen key (4 mm.).

Allen key (5 mm.).

Ø6,5 mm. (1/4") drill.

6 pcs. M6 (1/4") countersunk head screws and nuts (length depending on deck thickness).

6 x large washers or backing plate.

Ring spanner to match nuts.

Bedding compound

1. Remove screws (1).
2. Remove self-tailing arm (2) and drum (4).
3. Mark location of bolt holes using the template.
IMPORTANT: On this model the self-tailing arm (2) is fixed in one position.
Ensure correct positioning of the self-tailing arm, before marking and drilling the bolt holes.
4. Remove base (13). Be sure that no dust comes into contact with the winch while drilling.
5. Drill bolt holes Ø6,5mm (1/4").
6. Apply a light coat of bedding compound, ensuring that each bolt hole is bedded.
Keep drain grooves clear.
7. Fasten base (13) into place using 6 pcs. M6 (1/4") countersunk head screws. Use large washers or a backing plate.
8. Assemble in reverse order.
9. Check that the winch is functioning correctly:
The drum should operate smoothly, by turning the drum clockwise by hand.
The drum must not turn when trying to turn the drum anti clockwise.
While turning the winch handle clockwise the drum should turn.
While turning the winch handle anti clockwise the drum should not turn.

SERVICE INSTRUCTION

12ST ver. 3.0 – 12ST FS ver. 1.0

Tools required for service:

Allen key (4 mm.).

Screwdriver (small).

Winch handle.

ANDERSEN Winch grease.

1. Remove screws (1).
2. Remove self-tailing arm (2) and drum (4).
3. Insert a winch handle. Pull up the drive shaft (5) gently, while turning ratchet gear (15) carefully. Remove drive shaft (5).
4. Remove pawls (6) and arm springs (7).
5. Remove ratchet gear (15). DO NOT remove the insert plate (14) but make sure that the insert plate is positioned in its groove.
6. To release the roller bearing (8), gently insert a small screwdriver between roller bearing and base (13). Remove roller bearing.
7. Remove spring (12). DO NOT remove the pawl (11) and the spring (12) on the base.
8. Clean all parts in benzine. Remember to clean the gear teeth and roller bearing track.
9. Assemble in reverse order. During assemble, by the use of a small soft brush lightly grease all gear teeth, drive shaft, roller bearing, shafts, pawls, springs and bushings. Pawls should only be lubricated with a very thin film of ANDERSEN WINCH GREASE. It is very important that pawls can move freely.

IMPORTANT: When assembling the winch, check the functioning of each pawl by pushing the pawl against the spring. The pawls should move smoothly and automatically return to their normal position, where the pawls engage with the teeth. If the pawls do not function correctly, clean and lubricate the pawls and gears. Check the function of the pawls again to make sure that it works correctly. If the pawls do not work correctly replace the springs and recheck the functioning.

Malfunctioning pawls may lead to unexpected failure of a loaded winch resulting in material damage or fatal personal injury.

Service Kit No: 18 (art. no. 710018) contains spare parts for this winch.

**For current World Wide Distributor list please see:
www.andersenwinches.com**

PARTS LIST

12ST ver. 3.0 – 12ST FS ver. 1.0

POS.	QTY.	DESCRIPTION	ART. NO.
1.	3	Screws	ISO 7380-A4-M6×12
2.	1	Self-tailing arm	596711
3.	1	Self-tailing top	<i>Model ST</i> 537551
3.	1		<i>Model ST FS</i> 537511
3.1	1	Circlip	726400U
3.2	1	Top ring	782100
3.3	6	Screw	781811
3.4	1	Disc	<i>Model ST – (only for 537551)</i> 726310
4.	1	Drum comp.	726811
5.	1	Drive shaft comp.	726703
6.	2	Pawl	713200
7.	2	Arm spring	713300
8.	1	Roller Bearing	727400
9.	2	Bushing	<i>Not removable</i> 716501
10.	1	Screw	DIN 913-A4-M4X12
11.	1	Pawl	533400
12.	1	Spring	533500
13.	1	Base	731710
14.	1	Insert Plate	727500
15.	1	Ratchet gear	711701
	1	Service kit 18	710018

EXPLODED VIEW

12ST ver. 3.0 – 12ST FS ver. 1.0

POS. 3 - 537551

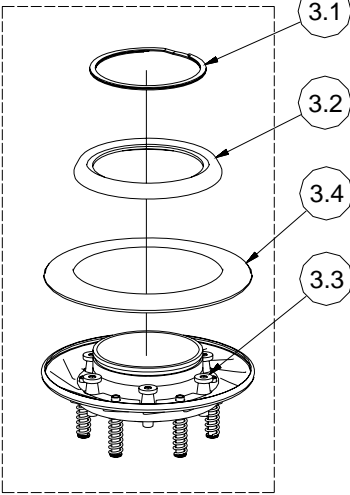

POS. 3 - 537511

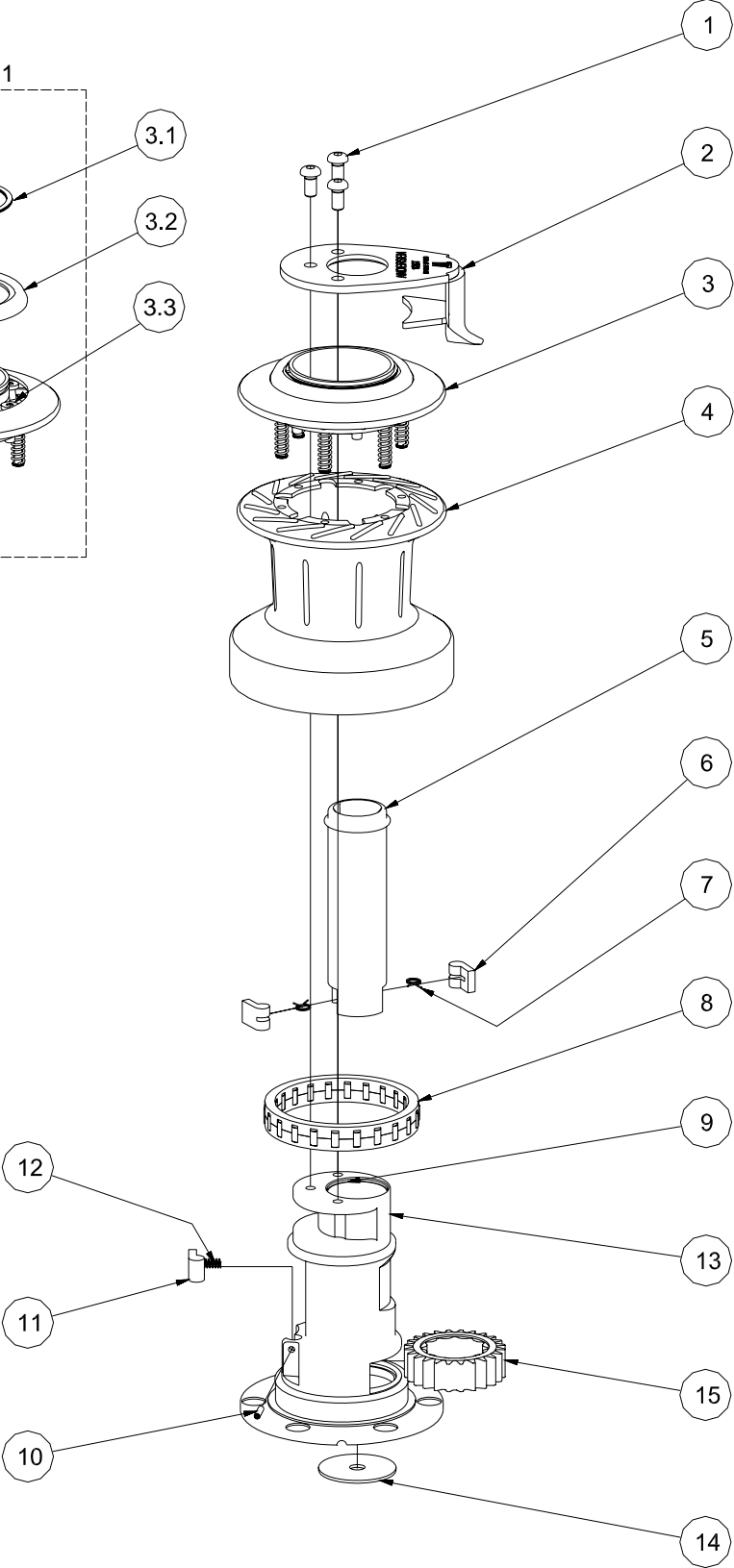
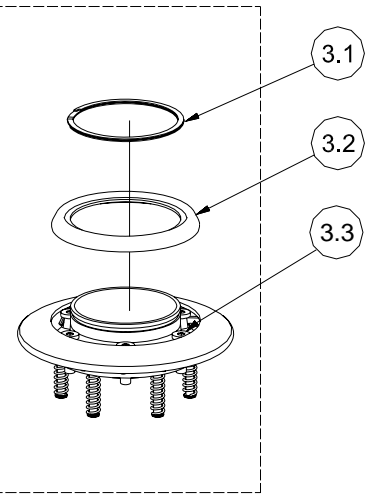

LIMITED WARRANTY

- 1.1 ANDERSEN issue a three-year warranty on all their products covering manufacturing and material defects on condition that the products are used in normal fashion. The warranty shall apply for three years from the moment ANDERSEN sell the product concerned (to the first buyer).
- 1.2 Within the period of the warranty, and in accordance with the terms of the warranty, ANDERSEN undertake to replace or repair all defective components which have been used in normal fashion.
- 1.3 However, the warranty is subject to the limitations and exceptions outlined below.
2. **Conditions and limitations:**
 - 2.1 ANDERSEN's liability shall be limited to repair or replacement of components which are defective owing to manufacturing or material defects.
 - 2.2 ANDERSEN assume no other liability than this, not even liability for indirect losses caused by defect concerned, including operating losses, loss of profits, or damage caused to real property or moveable property occurring while the product concerned is in the possession of the Buyer.
 - 2.3 The Buyer alone shall bear the responsibility and risk involved as to whether the product is suitable for the application intended. ANDERSEN assumes no liability in this connection.
 - 2.4 ANDERSEN assume no liability for defects which occur due to use of their products for purposes for which they are not intended, or for defects which occur owing to incorrect installation, corrosion, ultraviolet degradation, lack of maintenance, or any alteration or repair of the product carried out incorrectly by the Buyer. Finally, ANDERSEN assumes no liability for normal wear and tear, or for depreciation of value.
 - 2.5 Nor do ANDERSEN assume any liability for service carried out by anyone other than authorised representatives of ANDERSEN, unless such service is carried out pursuant to guidelines laid down by ANDERSEN and in accordance with good craftsmanship.
 - 2.6 The buyer shall inform ANDERSEN in writing of any defects with no undue delay once defects have been registered. Products being dealt with under the warranty shall be returned to ANDERSEN for repair unless any other agreement has been reached in writing.
 - 2.7 ANDERSEN shall not cover costs incurred by the Buyer in connection with the transport or wages involved in a warranty case. Such costs shall be met by the Buyer in full.
3. **Exceptions:**
 - 3.1 The warranty is only valid for one year in respect of components bought for the products concerned, such as electric motors, electric equipment, hydraulic pumps, motors and valves.
 - 3.2 ANDERSEN assume no liability for consequential damage of ships, equipment, property or people by defects in ANDERSEN's products.
 - 3.3 The company's products are subject to continuous development, and consequently ANDERSEN reserve the right to change designs and specifications without prior notice.