

Manual 52 STE/FS

2+2 SPEED

12V & 24V

GENERAL INFORMATION
MOUNTING INSTRUCTIONS
EXPLODED VIEW
CONNECTING DIAGRAM
WIRE DIMENSION AND FUSE SIZE



SERIAL NO: PS _____

CONGRATULATIONS

You have purchased an ANDERSEN high quality winch. This product is a result of many years of development and experience in producing winches for sailboats. This winch gives you a high degree of functionality and many years of safe and easy sail handling.

GENERAL INFORMATION

PLEASE READ THIS BEFORE INSTALLING YOUR ANDERSEN ELECTRIC WINCH.

The electric ANDERSEN winch has some built-in advantages:

- Easy to fit on your boat.
- Template included.
- Special tools included.
- Electric unit is turnable in 8 horizontal steps (45°).
- Easy to dismantle. Winch and electric unit can be dismantled separately.
- Winch in usual high **ANDERSEN** quality, featuring drum, roller bearings etc. of stainless steel. Electric unit is made of bronze which reduces corrosion, and guarantees easy dismantling for many years.
- Always the possibility of manual (2 speed) drive, just by inserting a standard winch handle. No shift-bottom of any kind.
- MODULAR POWER SYSTEM©: Always the possibility of changing to a hydraulic drive unit, a 2+1 SE© electric unit or the Compact© electric drive unit.

Mounting Installation:

Please follow the mounting instructions.

Ensure that each hole in the deck is bedded, including the big hole in the center.

IMPORTANT: Be careful not to put bedding compound IN the thread holes in the deck plate.

Ensure that the sealing ring (O-ring) on top of the gear unit is placed in its groove.

Electric Installation:

Please follow the installation instructions.

WARNING: Do not use smaller wire, than recommended in the diagram. This can cause malfunction of the winch and in worst case - FIRE. The wires should always be as short as possible.

Normal Use:

The electric motor has built-in overload circuit breaker, which breaks the circuit, before the motor gets too hot.

After a short period of cooling, depending on temperature under deck, ventilation etc., the winch will be ready for electrical operation again.

Meanwhile, if necessary, just insert a standard winch handle, and use the winch as a 2 speed manual winch. We recommend to remove the handle when operated electrically -

From a safety point of view.

General Service Instructions:

The electric drive unit is lubricated sealed and requires no further maintenance.

The part *on* deck is a standard self tailing winch, and needs regular service. We recommend

dismantling, cleaning and lubrication *once* a year. Under extensive use, such as racing, charter or blue water sailing, we recommend to make a further lubrication check during the one year period.

We strongly recommend always to use ANDERSEN WINCH GREASE© when lubricating your winch. ANDERSEN WINCH GREASE© is a high quality silicone/Teflon® grease.

MOUNTING INSTRUCTION

52 STE/FS 2+2 SPEED (- VER.2.5)

12V & 24V

FIG.1

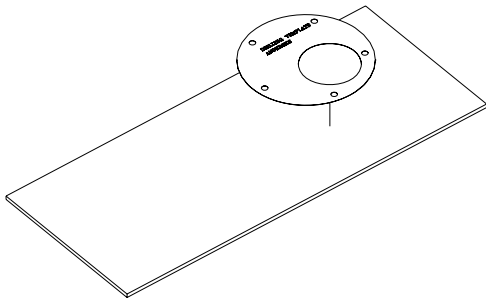

FIG.3

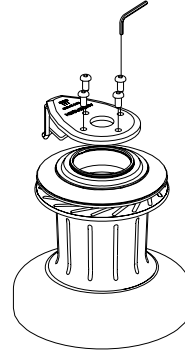

FIG.2

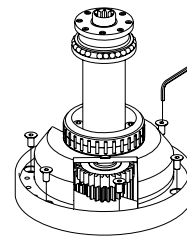
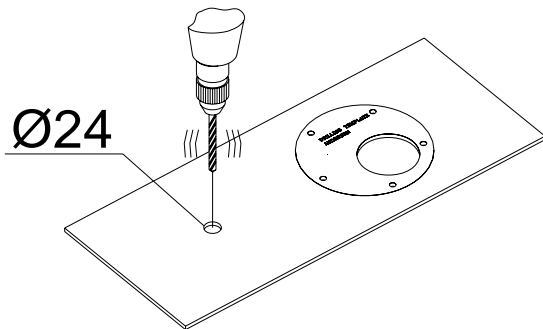
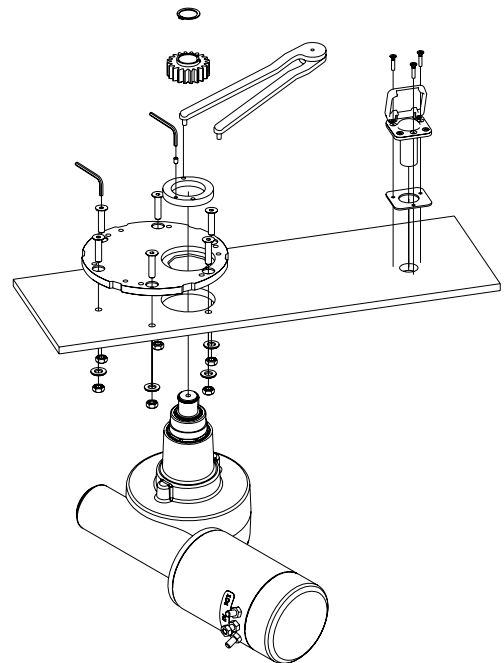
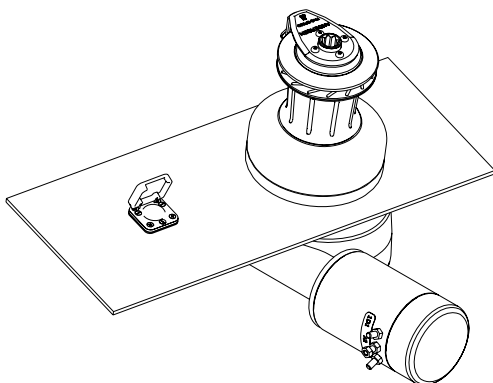

FIG.4



Important Installation Information!

It is extremely important that your motor is aligned with your winch. Non-aligned motors will be noisy and gear wear will be accelerated.

To insure that your motor is aligned properly the motor flange must be flush with the deck plate and the eight-sided nut must fit snugly into the octagon in the deck plate.

This can be achieved with the help of the following:

- Drill the hole through the deck wider than the motor flange. When mounted there must be free space between the deck and the flange.
- Clean the deck hole before attempting to install the motor so that the motor flange does not catch splinters of fiberglass or wood when being inserted through the deck.
- Insure that the underside of the deck plate is clean and free from resin, varnish or sealants.
- Do not use a sealant between the flange and deck plate. An o-ring insures a waterproof connection. Extra waterproofing can be achieved by applying sealant to the top of the deck plate next to the mounting nut after installation.
- Insure that the locking screw on the mounting nut is not protruding beyond the contact surface before tightening the mounting nut. Tighten the locking screw when the mounting nut is securely in place.

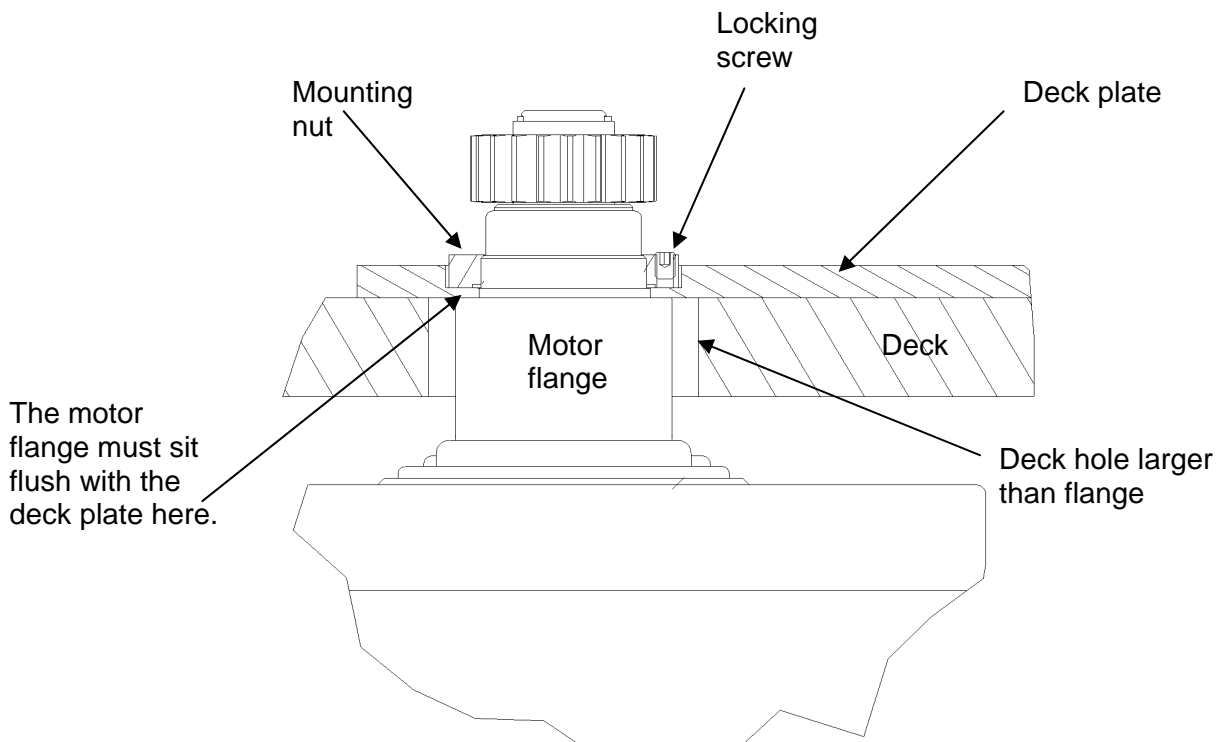

EXPLODED VIEW

52 STE/FS 2+2 SPEED (- VER.2.5)

12V & 24V

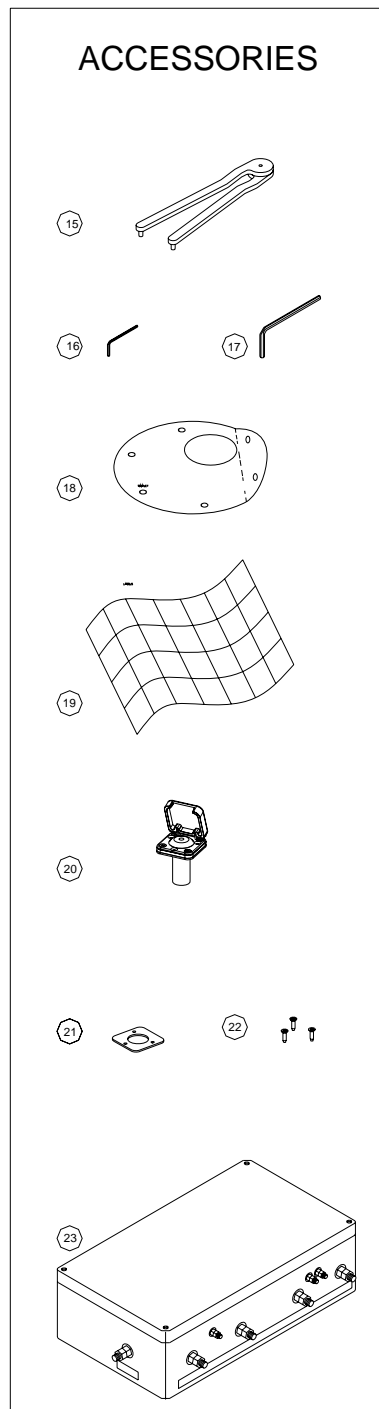
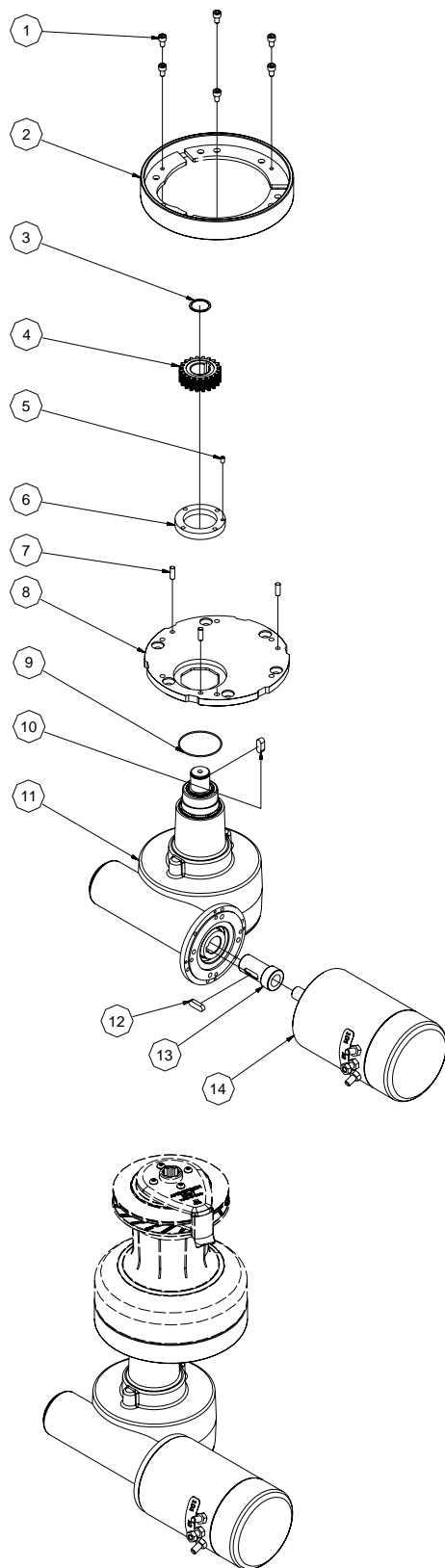

PARTS LIST

52 STE/FS 2+2 SPEED (- VER.2.5)

12V & 24V

POS	QTY	DESCRIPTION	ART. NR.
1	6	SCREW	DIN7991-M8X20-A4
2	1	BASE COVER, STANDARD	734301
2	1	BASE COVER, FS MODEL	734330
3	1	CIRCLIP	RD829680
4	1	GEAR WHEEL	981500
5	1	SCREW	DIN916-A4-M5X8
6	1	NUT FOR GEARBOX	584510
7	3	PIN	713401
8	1	DECKPLATE	746902
9	1	O-RING	RD100074
10	1	KEY	DIN6885-A-8X7X2
11	1	WORM GEAR UNIT	750303
12	1	KEY	591500
13	1	MOTOR BUSHING	584800
14	1	ELECTRIC MOTOR 12V	RD100334
14	1	ELECTRIC MOTOR 24V	RD100335
15	1	PIN SPANNER	RD738000
16	1	ALLEN KEY 3MM	593000
17	1	ALLEN KEY 5MM	592800
18	1	TEMPLATE	RD100213
19	1	SWITCH LABELS	RD100029
20	1	SWITCH	581900
21	1	SEALING	735050
22	3	SCREW	RD100025
23	1	SWITCH BOX COMPLETE 12V	990112
23	1	SWITCH BOX COMPLETE 24V	990124

CONNECTING DIAGRAM

52 STE/FS 2+2 SPEED

12V

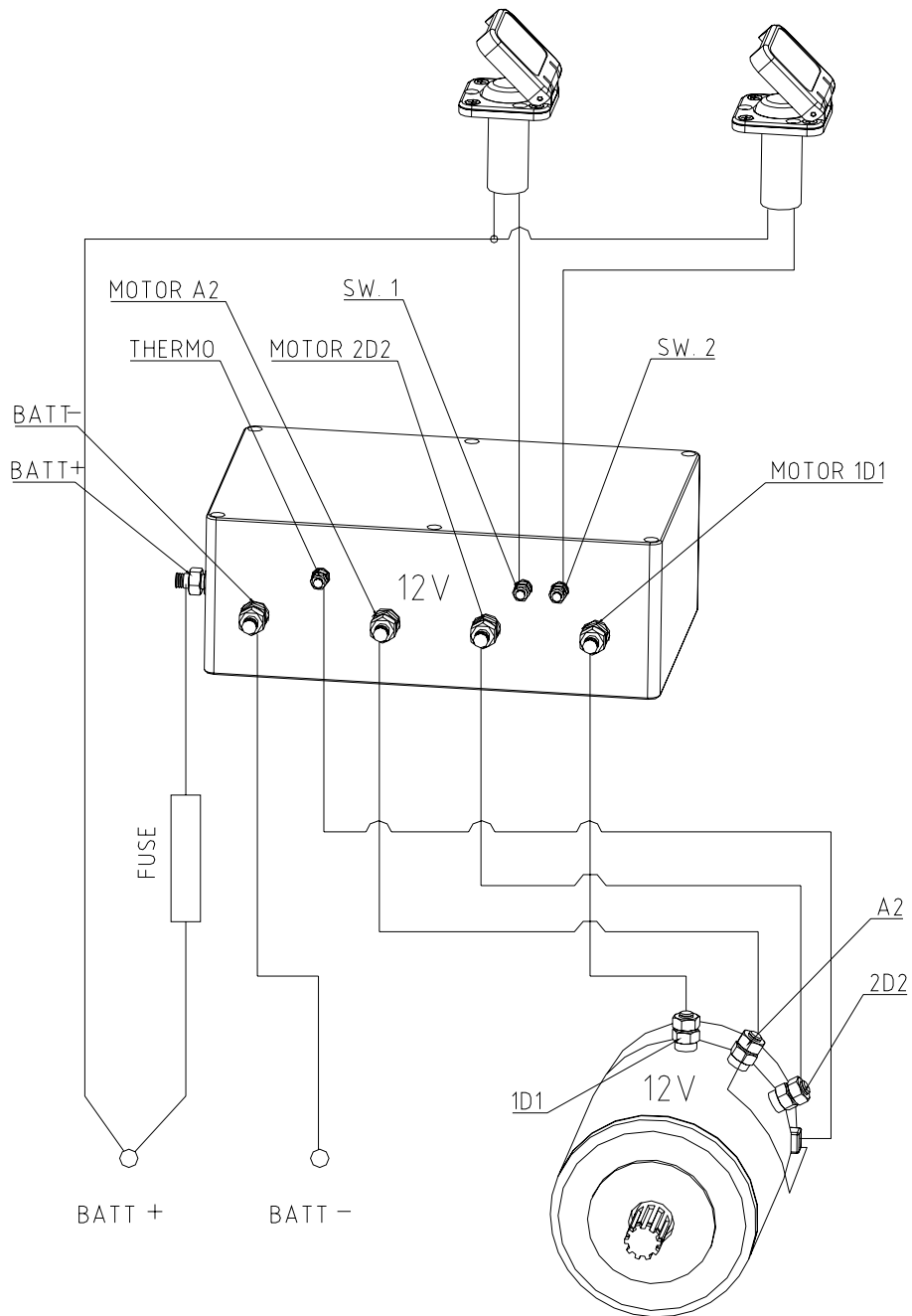

IMPORTANT : Fuse must be of a slow blow type !

CONNECTING DIAGRAM

52 STE/FS 2+2 SPEED

24V

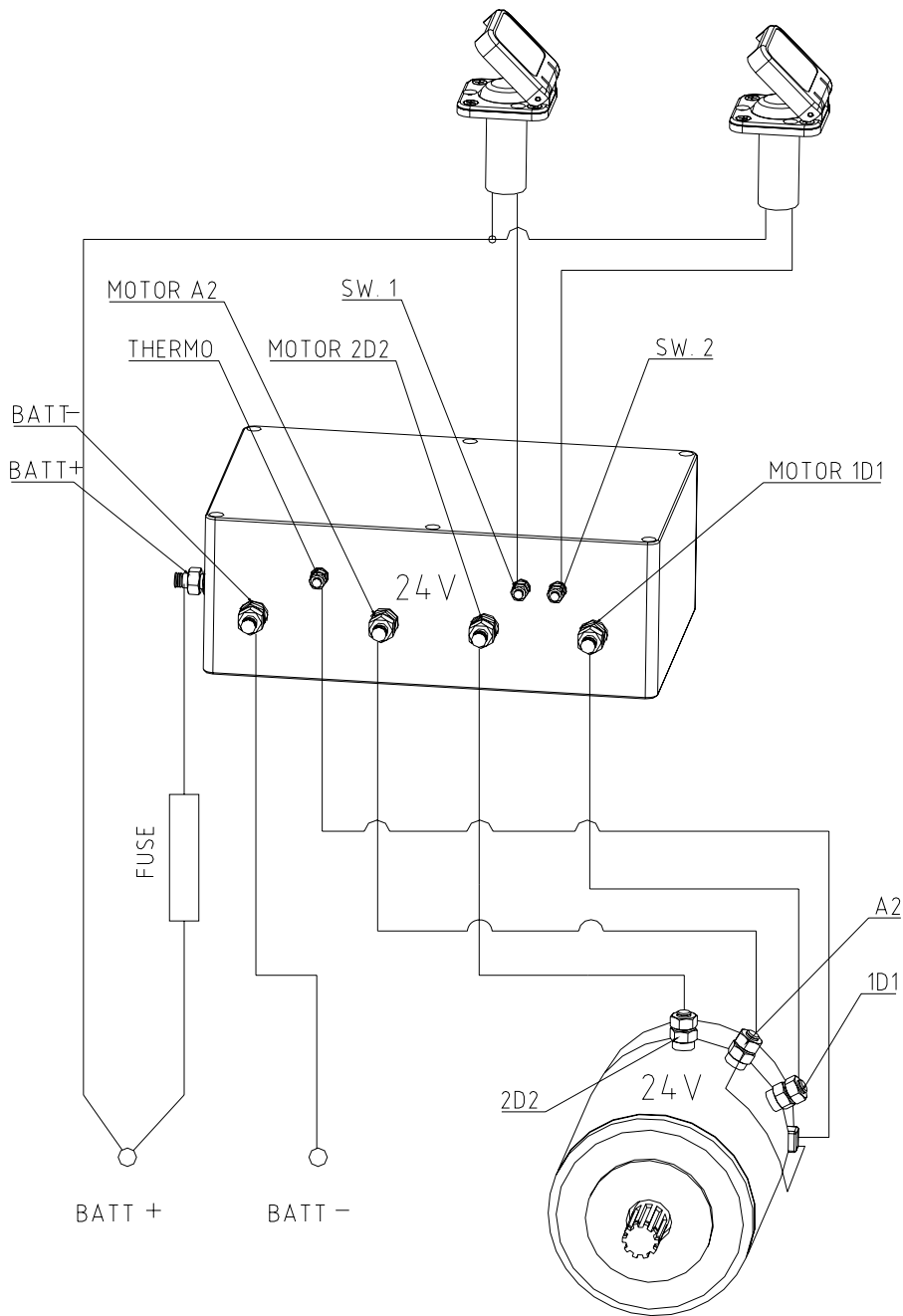

IMPORTANT : Fuse must be of a slow blow type !

WIRE DIMENSIONS & FUSE SIZES

WINCH	WIRE LENGTH*	12V. DC			24V. DC		
		WIRE	FUSE	BAT. CAP.	WIRE	FUSE	BAT. CAP.
46 STE 2+2 SPEED	0-3 m / 0-10 ft	35 mm ²	125 A	240 Ah	25mm ²	76 A	120 Ah
	3-8 m / 10-27 ft	50 mm ²	160A	240 Ah	25mm ²	100 A	120 Ah
52 STE 2+2 SPEED	0-3 m / 0-10 ft	35 mm ²	125 A	240 Ah	25mm ²	76 A	120 Ah
	3-8 m / 10-27 ft	50 mm ²	160A	240 Ah	25mm ²	100 A	120 Ah
58/62 STE 2+2 SPEED	0-3 m / 0-10 ft	50 mm ²	160 A	360 Ah	25mm ²	100 A	180 Ah
	3-8 m / 10-27 ft	70 mm ²	200 A	360 Ah	35mm ²	125 A	180 Ah
68/72 STE 2+2 SPEED	0-3 m / 0-10 ft	70 mm ²	200 A	360 Ah	25mm ²	100 A	180 Ah
	3-8 m / 10-27 ft	95 mm ²	224 A	360 Ah	35mm ²	125 A	180 Ah
78 STE 2+2 SPEED	0-3 m / 0-10 ft	n.a.	n.a.	n.a.	50mm ²	200 A	360 Ah
	3-8 m / 10-27 ft	n.a.	n.a.	n.a.	95mm ²	224 A	360 Ah

*) *WIRE LENGTH* is defined as the distance from battery to switch box + the distance from switch box to motor.

**For current World Wide Distributor list, please see:
www.andersenwinches.com**